

## USER MANUAL

AUGUST 2016

### OPTO-ISOLATOR BOARD

MM107

This breakout board is the interface between a serial TTL and a RS485 bus, a serial interface too but in balanced configuration consisting of two wires referred to ground, rather than unbalanced (only one conductor connected to ground) as in the classic TTL.

The RS485 is a simplex data communication line specifically designed to operate in electrical noisy environments and on long distances, up to 1.2 km.

Its performances about electrical noise immunity and long operating distances are due to the current loop and to the high signaling voltage range implemented by the protocol.

RS485 drivers (transmitting stages) send to the two wires a differential voltage to ground, having so a mutual wire-to-wire signal voltage that is double the level obtainable on the unbalanced line. RS485 is a bus, so it is possible to connect in parallel (to the two line wires) many devices, the farthest of those must be terminated with a 120 Ohm stub resistor between A and B wire. The maximum data rate is 35Mbps up to 10m distance or 100kbps at 1200m.

The RS485 line wires are connected to A pin (pin 6) and B pin (pin 7) and are connected to the corresponding pins on the breakout board.

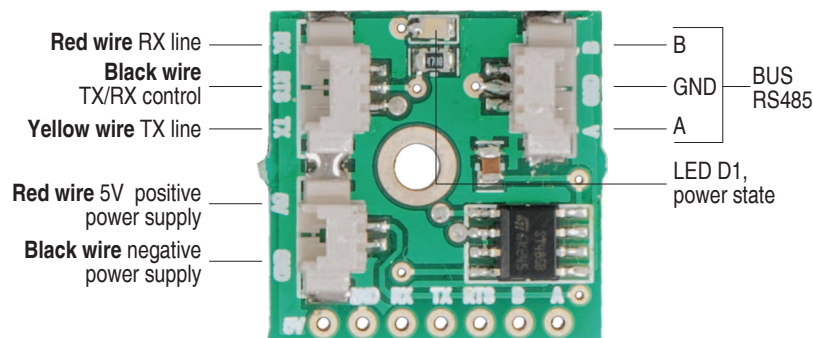
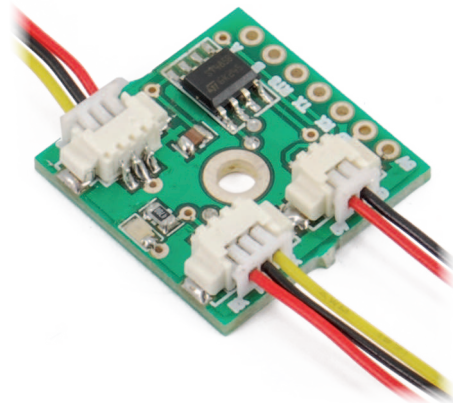

To offer the best flexibility, all the lines (power supply, RX, TX, serial TTL RTS, RS485 A and B) are replicated to the side board areas and to the pin-strips, making it easy to plug on other boards.

The LD1 LED completes the board, indicating when ON that the power supply (5V that is the expected input voltage) is ok; a ceramic capacitor C1 filters the power input line.

The integrated communication circuit accepts on A and B common mode voltages between -7V and 12V (referred to ground) and the standby power consumption (RX and TX drivers off) is limited to 300 uA. When off, the TX driver puts the output state to high impedance, so not to load the bus.

Up to 64 devices can be connected to the bus: they must be the same type and only one at time can access the bus (TX).

The transmitter stage has a current limiter that puts the line to high impedance. This behavior is good to avoid damages in case of short-circuit and in case more than one TX is enabled at the same time on the line.

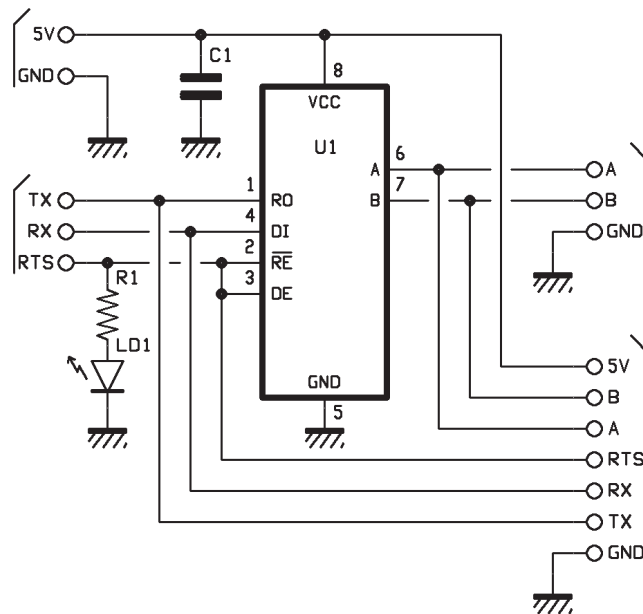

WWW.VELLEMANPROJECTS.EU