

USER MANUAL

AUGUST 2016

OPTO-ISOLATOR BOARD

MM106

This breakout board has been conceived so to supply whichever circuit operating at a TTL level with an opto-isolated input: that is to say, in order to transmit a logic condition between two circuits, while still keeping them separated from a galvanic point of view. The heart of the circuit is the TLP181 photocoupler, composed of an infrared LED that is connected between pins 1 (anode) and 2 (cathode), leaning towards the base of a NPN phototransistor, that is in turn connected to the collector at pin 5, and to the emitter at pin 4 (in this photocoupler, the base is not connected to the exterior via pins).

The breakout board's power source is a 5V DC one, and the absorption is a very small one: just 1 milliampere at most. Thus you may couple it to any circuit, even if battery-powered, or when using small photovoltaic panels or other Energy Harvesting solutions. The input for this circuit is located at the IN contacts, to which it is possible to apply a direct voltage, with a value between 6 and 30 volts, and also a sinusoidal alternating current having width between 5 and 30 volts. In the first case, the output phototransistor's collector will be brought at a logical zero (a few hundreds millivolts) for the whole duration of the input voltage's presence, while in the second one it will pulse between 5V and the logical 0, with a trend that will reflect the sinusoidal alternating current.

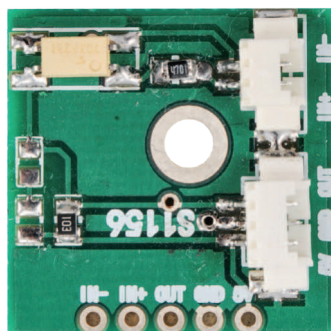
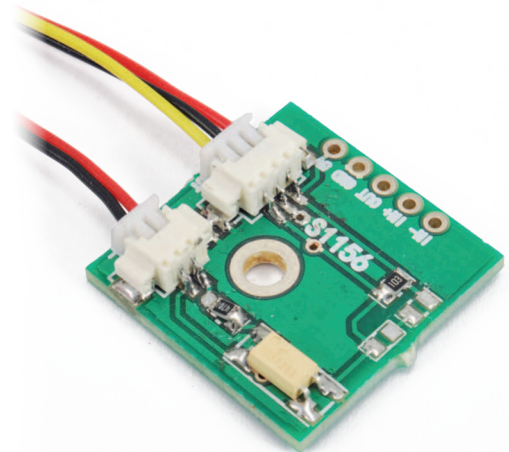

- **Black wire** (negative) circuit's input
- **Red Wire** (positive) circuit's input
- **Yellow wire** output signalling voltage found
- **Black wire** GND (negative) power source
- **Red wire** 5V (positive) power source

The photocoupler's input LED will be turned on even by quite feeble currents: on the order of a milliampere. The C.T.R. (Current Transfer Ratio), that is to say the ratio between the output current (in this case it is the phototransistor's collector current...) and the input current is 60% when saturating and up to 5 times in the best conditions (input current being around 5 mA, and collector-emitter voltage being 5V, but that is not our case).

The contacts (input, output, power source) are available both as placed on the circuit board's sides, and on a line of spacing 2,54 mm bonding pads, which is ready to host a pin-strip enabling the insertion in other boards.

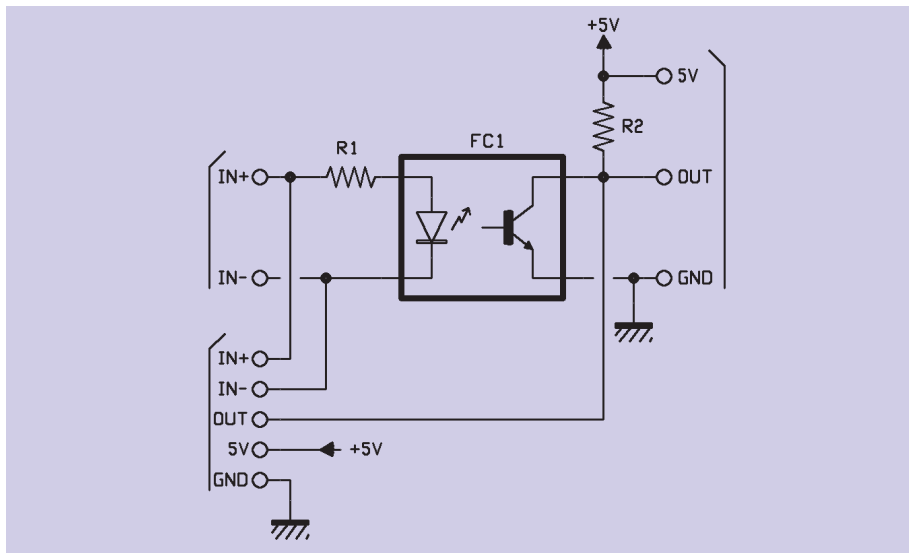

WWW.VELLEMANPROJECTS.EU