

The TR-12 module is a digital Recorder / Player for voice, music or sound with a non volatile storage memory having 2 minutes as maximum capacity.

It allows to share the total time in different combinations as concern time and number of messages, with a maximum of 15 messages of 8 sec. and a minimum of 1 message of 1 minute or 2 minutes.

It includes a direct output to loudspeaker with 5W as maximum power and volume control.

24V DV opto coupled control input, with electrical insulation.

It allows to play in normal or repetitive mode, to record through a microphone or RCA input, and indicator leds.

It can be installed in a DIN-RAIL Ref. C-7591

#### TECHNICAL CHARACTERISTICS.

- Voltage..... 24 V. D.C.
- Min./Max. consumption..... 110 / 400 mA.
- Inputs control signal..... From 3 to 24 V.DC
- Minimum control input voltage..... 10 mA.
- Sampling Frequency..... 8 KHz.(not variable).
- Output Impedance..... 4 - 8 Ohms.
- Output power..... 5 W. (RMS at 4 Ohms).
- Automatic Gain Control, (AGP)..... (Internal AGP)
- Protection against inversion of polarity..... Feed input.
- Operating temperature..... -25°C up to +55°C
- Maximum wires section for connection terminals..... 2,5mm
- Net weight:..... 180gr
- DIN Rail fixing (C-7591) / Screw to fix in 4 points
- Operating indication: 5mm Red Led (PWR)
- Recording selection indication: 5mm Red Led (REC)
- Playing indication: 5mm Green Led (PWR)
- Running indication: 5mm Green Led (RUN)
- Repeating messages indication: 5mm Yellow Led (REPEAT)
- Rules: 89/336/CEE Electromagnetic Compatibility and its modifications 32/31/CEE and 93/68/CEE.

TR-12

#### INSTRUCTIONS.

##### Description.

The TR-12 offers 15 numerated inputs with control through positive signal from 3 to 24 V DC. Each input will activate and allow to record or to play the corresponding message. The assigned time for each message will depend on the previous configuration, where the module allows to select according to the number of operative messages, regarding the memory capacity sharing out.

The messages record can be done through the incorporated microphone or through the RCA input allowing the connection between other audio devices. The module's memory is not volatile; maintaining stored all messages, even if the circuit is not supplied.

##### Instalación.

**INSTALLATION.** The module's installation has to be preferably done into an enclosure or a rack, correctly ventilated, avoiding any contact between the circuit and metal objects.

Do not install the device in humid places, under high temperatures, or in contact with liquids.

Do not supply the module before to finish its installation. Please carefully read this instruction manual.

**Control signal.** Composed by fifteen connection inputs, they are electrically insulated from the rest of the circuit. For this reason, it is necessary to connect the negative from the signal which you have to excite inputs to the common negative of the control inputs. We recommend you to minimize at the maximum the wiring length, using shielded cable.

**RCA input.** The RCA input allows to inject an external audio signal to the circuit, to make easier the direct sound recording coming from other devices. Nevertheless, the signal level coming from these devices has to be inferior to the maximum level admissible by the circuit (36 mV. Vpp), otherwise the module will be damaged. For this reason, you only can connect to the RCA input the headphone output of devices with an output not referred to the ground (most of standard audio player). Respect the polarity

##### Installatuon, (Part II).

of the RCA connector (Fig.1) and consult the Recording paragraph, where it is indicated the RCA selection mode as source to record.

Fig. 1. RCA Connector  
• Polarity of the Audio Input.

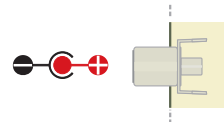

**Loudspeaker output.** The maximum power offered by the device is 5W. Anyway, we suggest you to use a 10W loudspeaker as minimum, with an impedance of 4 or 8 Ohms. For this output, you can use standard parallel cable.

**Fixing.** The device includes 4,5mm x 4 holes to fix it. Additionally, through Cebeq C-7591 guides, you can install it on a DIN rail.

##### Power Supply.

The TR-12 circuit had to be supplied with a power supply correctly filtered. We recommend you to use a short circuitable power supply with a low ripple level. Do never use basic power supplied or rectifiers to avoid to damage the module's operating mode. For this reason, we suggest you to our Cebeq Ref. FE-136 power supply, which has been developed to perfectly answer to the circuit needs.

Connect the positive and the negative of the power supply to the positive and negative terminal of the input module. See the general wiring map.

**Note:** Install a fuse and a switch has it is indicated on the schedule. Both are necessary for the module's protection as well as for your own safety, as it is required by the "CE" regulations.

Consult the corresponding power supply's instruction manual. Then, Verify that the assembly is correct.

## INSTRUCTIONS.

### Indicators.

There are five indicator leds on the circuit.

**Pwr Led.** (Red). It will light on when the device is supplied.

**Repeat Led.** (Yellow). It will light on to indicate the activation of the Repetitive Play function.

**Rec. Led.** (Red). It will light on only when the module's Record mode is selected.

**Play Led.** (Green). It will light on only when the module's Play mode is selected.

**Run Led.** (Green). From the beginning till the end of the recording register or during a message playing, the Run led will be intermittently light on.

### Dip SET Functions.

The different module's functions like messages number, repetitive operating mode, etc... are configured through the Dip composed by 8 micro switches and incorporated on the circuit. It is indicated as SET. See Fig.2.

Fig. 2. Dip SET. Functions assigned to each switch.

● To configure functions According to the Switch position on On or Off.

		ON	OFF
Memory Capacity →	Switch 5	120 seconds	60 segundos
Mute Function →	Switch 6	Sound on Loudspeaker	Silence on Loudspeaker
Repeat Function →	Switch 7	Activated	Deactivated
Recording Protection →	Switch 8	Recording Allowed	Recording Denied

### To configure Number and Time of messages.

The module allows to operate with a single message with a maximum of 1 minute, or different combination of numbers and the consecutive division of the assigned time to each one. According to the ON or OFF position for switches N° 1, 2, 3, and 4 you will obtain a different combination. See Fig. 3.

Fig. 3. Dip SET. To configure the number/time of messages.

● Number of messages according the combination of switches 3, 4, 5 and 6.

	Switch 1	Switch 2	Switch 3	Switch 4
15 messages of 4 sec. →	On	On	On	On
12 messages of 5 sec. →	Off	On	On	On
10 messages of 6 sec. →	On	Off	On	On
7 messages of 8 sec. →	Off	Off	On	On
6 messages of 10 sec. →	On	On	Off	On
5 messages of 12 sec. →	Off	On	Off	On
4 messages of 15 sec. →	On	Off	Off	On
2 messages of 30 sec. →	Off	Off	Off	On
6 messages of 8 sec. + 6 messages of 2 sec. →	On	On	On	Off
5 messages of 10 sec. + 5 messages of 2 sec. →	Off	On	On	Off
4 messages of 10 sec. + 10 messages of 2 sec. →	On	Off	On	Off
3 messages of 12 secg. + 12 messages of 2 sec. →	Off	Off	On	Off
5 messages of 8 sec. + 5 messages of 4 sec. →	On	On	Off	Off
4 messages of 10 sec. + 5 messages of 4 sec. →	Off	On	Off	Off
2 messages of 10 sec. + 10 messages of 4 sec. →	On	Off	Off	Off
1 messages of 60 sec. →	Off	Off	Off	Off

Through the switch N°5 in OFF position, time assigned to each message will correspond to the indicated one by the table. Placing the switch in ON position, the module's memory capacity will be automatically doubled as well as the assigned time per message.

Recording and playing will be conditioned by this selection, because both have to be done in the same messages configuration that originally selected. Otherwise, the module doesn't play correctly.

Do not forget that the number of selected messages will be always assigned from the message input N°1 and so on. For instance, if you have configured the module to operate with 8 messages, only inputs N°1 and 10 will be operative, and the rest of inputs will be not operative.

### Recording.

Protection against involuntary recording. The module includes a protection against the involuntary recording. If you place the switch 8 in position OFF, the device denies the recording. At the opposite, if you place the switch 8 in ON position, the circuit will allow it.

### Recording through microphone.

To record through a microphone, you have to close JP1 and JP2 jumpers on the circuit and to not introduce signal through the RCA input (See Fig.4).

### Recording, (Part II).

To record, it is necessary to get closer the microphone and to emit the sound with deep and power. The module includes an automatic gain control (AGC), allowing the stabilisation of the signal level caught by the microphone.

### Recording through RCA input.

To record through the RCA input, you have to open JP1 and JP2 jumpers (See Fig.4). Then when you will start a recording, the circuit will store in its memory the audio signal caught through this input.

Fig. 3. To select the Audio Input source for Recording.

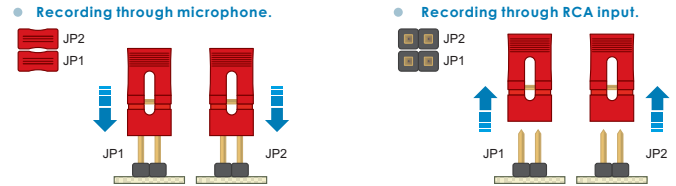

### Recording process.

The recording function is selected closing the REC Jumper (the Red Led will light on).

To start the recording you have to momentary connect the control input corresponding to the message on wish you want to record.

The recording will be automatically stopped when the maximum time of the message is exhausted.

During the recording process, it is recommended to maintain activated the Mute function (switch 6 in OFF position), explicate later.

### Playing.

**Mute Function.** This function will operate independently of playing inputs. When the switch 6 is in OFF position, the mute function will maintain in silence the loudspeaker output. When the switch 6 is in ON position, the module will allow the audio output through the loudspeaker.

**Playing process.** The playing function will be activated when the two terminals of Rec input are open (Play Led light on).

The playing of each message is independently executed when the corresponding control input (24V positive signal) is activated. The playing is automatically stopped when you arrive at the end of the recorded message, independently of the maximum time accepted by the memory. In the repetitive function, once you arrive at the end of the recorded message, the circuit will automatically restart the playing.

The module doesn't allow to activate a message if it is already playing a message. You have to wait the end before to activate any other message.

**Repetitive playing.** The repetitive function allows to cyclically play a message till the selection terminal of this one are closed. To activate this function, you have to use the switch 7. When this one is in ON position, the module will allow the repetitive function. With the switch 7 in OFF position, at the end of the recorded message, the playing will be stopped (even if selection terminals of this message are still closed).

**Volume control.** The device allows to adjust the playing volume level through the potentiometer inserted on the circuit, and indicated as "Volume". We strongly recommend you to not place the potentiometer at the maximum to avoid to saturate the output, distorting the sound.

### Warranty and Technical consultations.

All cebek modules have a total warranty of 3 years as concern components and labour man.

All damage, error or mistake due to problems independent from the circuit, connection, installation or operating mode, as well as wrong handling are not included in this warranty. More over it will be necessary the purchase invoice of this module for any claim.

This manual (documentation) can be reviewed or modified without any previous communication, and it doesn't involve FADISEL. S.L.

The use of any of the FADISEL modules' mentioned in this manual provoke the acceptance of these commercial terms and correspondent warranty.

To contact our technical depart. Please contact: - sat@cebek.com

or by fax (+34) 93.432.29.95

or by mail at the following address: FADISEL - c/Quetzal, 17-21 - 08014 Barcelona - SPAIN.

ELECTRICAL DRAWING.

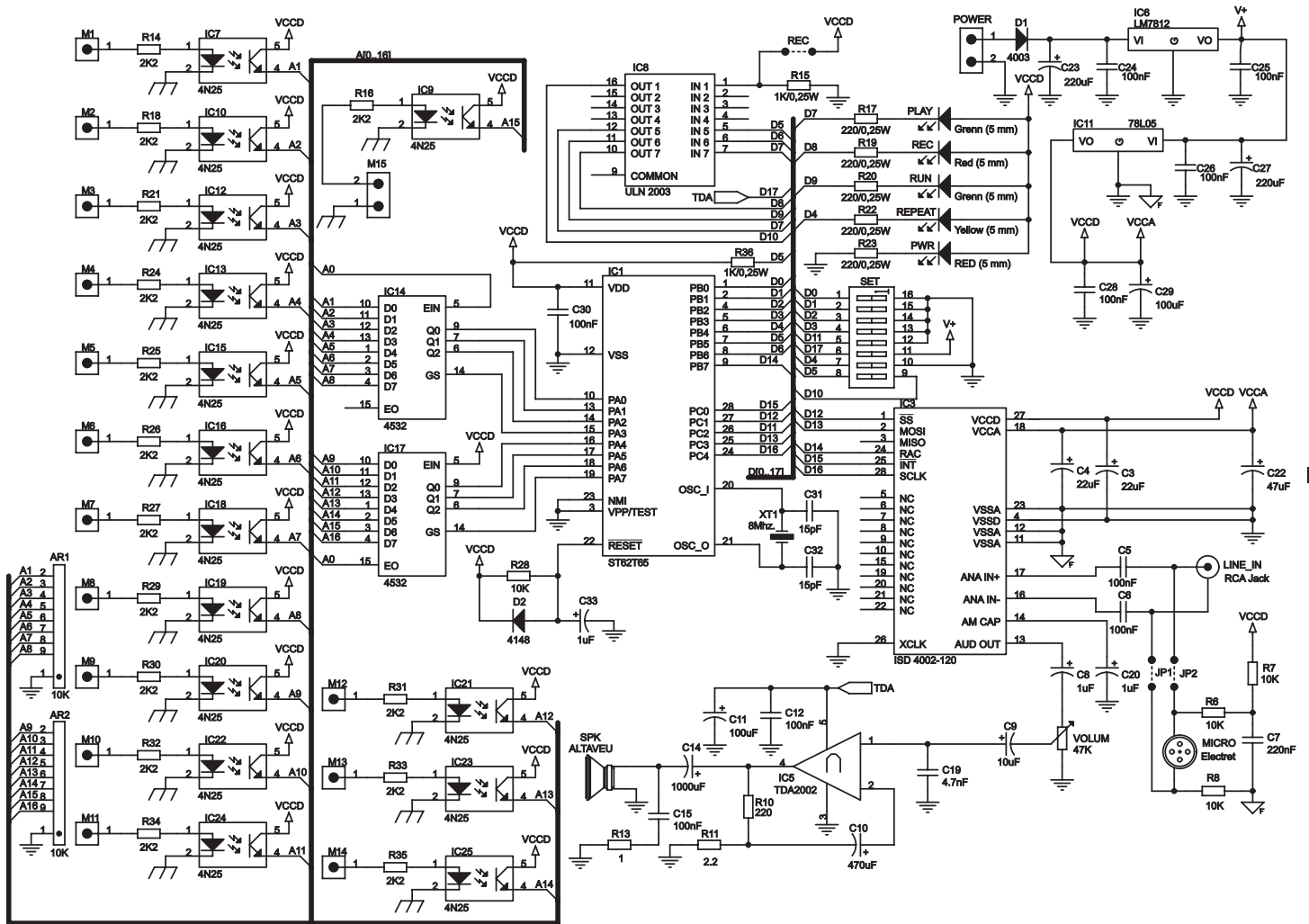

MECHANIZED and WIRING.

