

QUASAR KIT No. 1055

FM RADIO RECEIVER ELECTRONIC CONSTRUCTION KIT

GENERAL DESCRIPTION

This is a very easy to build FM receiver using the TDA7000 which is a complete FM receiver in a single IC. It covers the FM band from 88 to 108 MHz and the circuit incorporates a 5 Watt audio amplifier in another IC the TDA2002.

HOW IT WORKS

All the usual receiver operations are performed within the TDA7000 which has the following technical specifications:

Sensitivity: 1.5 μ V

S/N ratio: 60 db

Distortion: 0.7 %

Working voltage: ... 6-12VDC

The receiver uses a varicap for the tuning with a multiturn potentiometer. The use of the varicap diode increases the circuit stability and also minimizes the setting up adjustments necessary. In fact there are absolutely no adjustments to be made as the coils are already wound and the only things you have to do is to tune into a station adjust the volume andenjoy the music. The transistor TR1 is used as a preamplifier to bring the signal at a sufficiently high level in order to drive the power amplifier which consists of one IC the TDA2002 and is capable of delivering up to 5 Watts.

CONSTRUCTION

First of all let us consider a few basics in building electronic circuits on a printed circuit board. The board is made of a thin insulating material clad with a thin layer of conductive copper that is shaped in such a way as to form the necessary conductors between the various components of the circuit. The use of a properly designed printed circuit board is very desirable as it speeds construction up considerably and reduces the possibility of making errors. Quasar Kit boards also come pre-drilled and with the outline of the components and their identification printed on the component side to make construction easier. To protect the board during storage from oxidation and assure it gets to you in perfect condition the copper is tinned during manufacturing and covered with a special varnish that protects it from getting oxidized and also makes soldering easier. Soldering the components to the board is the only way to build your circuit and from the way you do it depends greatly your success or failure. This work is not very difficult and if you stick to a few rules you should have no problems. The soldering iron that you use must be light and its power should not exceed the 25 Watts. The tip should be fine and must be kept clean at all times. For this purpose come very handy specially made sponges that are kept wet and from time to time you can wipe the hot tip on them to remove all the residues that tend to accumulate on it.

DO NOT file or sand paper a dirty or worn out tip. If the tip cannot be cleaned, replace it. There are many different types of solder in the market and you should choose a good quality one that contains the necessary flux in its core, to assure a perfect joint every time.

DO NOT use soldering flux apart from that which is already included in your solder. Too much flux can cause many problems and is one of the main causes of circuit malfunction. If nevertheless you have to use extra flux, as it is the case when you have to tin copper wires, clean it very thoroughly after you finish your work. In order to solder a component correctly you should do the following:

- Clean the component leads with a small piece of emery paper.
- Bend them at the correct distance from the component's body and insert the component in its place on the board.
- You may find sometimes a component with heavier gauge leads than usual, that are too thick to enter in the holes of the p.c. board. In this case use a mini drill to enlarge the holes slightly. Do not make the holes too large as this is going to make soldering difficult afterwards.
- Take the hot iron and place its tip on the component lead while holding the end of the solder wire at the point where the lead emerges from the board. The iron tip must touch the lead slightly above the p.c. board.
- When the solder starts to melt and flow wait till it covers evenly the area around the hole and the flux boils and gets out from underneath the solder. The whole operation should not take more than 5 seconds. Remove the iron and allow the solder to cool naturally without blowing on it or moving the component. If everything was done properly the surface of the joint must have a bright metallic finish and its edges should be smoothly ended on the component lead and the board track. If the solder looks dull, cracked, or has the shape of a blob then you have made a dry joint and you should remove the solder (with a pump, or a solder wick) and redo it.
- Take care not to overheat the tracks as it is very easy to lift them from the board and break them.
- When you are soldering a sensitive component it is good practice to hold the lead from the component side of the board with a pair of long-nose pliers to divert any heat that could possibly damage the component.
- Make sure that you do not use more solder than it is necessary as you are running the risk of short-circuiting adjacent tracks on the board, especially if they are very close together.
- When you finish your work cut off the excess of the component leads and clean the board thoroughly with a suitable solvent to remove all flux residues that still remain on it.

The construction of the receiver should not present any problem as it is very straightforward and there are no particularly critical points in the circuit. Start working by taking all the components out of the packet and identifying them. Solder in their places the IC socket, the pins and the coils as these are the components which are the least sensitive to heat. Solder then the resistors on the p.c. board making sure that the right resistor goes to the right place. In order to help you with the identification of the resistors the colours that correspond to each value are printed next to it in the parts list. When you

finish soldering the resistors do the same with the capacitors making sure that the electrolytics are inserted the right way round as they have positive and negative poles should be connected correctly.

You can then solder the diodes the transistor and the power amplifier IC. The power amplifier can get quite hot if the receiver is used for long periods of time at high volume and it is advisable to use the heatsink provided to dissipate the heat.

It is better to mound the TDA2002 to the heatsink before soldering it to the p.c. board. The leads of the TDA2002 are preshaped and they should fit easily into the holes made on the board for the IC. Make sure that the IC does not get overheated as you solder it. Use flexible cable to connect the speaker and the two potentiometers with the p.c. board and connect a piece of wire at point 4 at the other end of which you will connect the antenna. Insert the TDA7000 in its socket and make a visual inspection of the work done so far. If everything looks all right then you can proceed with the testing of the receiver. Connect a power supply or a battery (9-12 VDC) at points 1 (-) and 2 (+) of the circuit. If the receiver is working, and you increase the volume you should hear a loud «hiss» from the speaker and turning the potentiometer R3 should bring in a station. The reception should be very clear and the high sensitivity of the receiver should make tuning even to the weakest of the stations a simple matter.

IF IT DOESN'T WORK

- Check your work for possible dry joints, bridges across adjacent tracks or oldering flux residues that usually cause problems.
- Check again all the external connections to and from the circuit to see if there is a mistake there.
- See that there are no components missing or inserted in the wrong places.
- Make sure that all the polarized components have been soldered the right way round. - Make sure that the supply has the correct voltage and is connected the right way round to your circuit.
- Check your project for faulty or damaged components.

If your project still fails to work, please contact us for information about our Get-You-Going service.

PARTS LIST

All board mounted components including 8 ohm loudspeaker, heatsink, pins, cable, solder, printed circuit board, assembly instructions including schematics and detailed parts list are supplied when you purchase the kit.

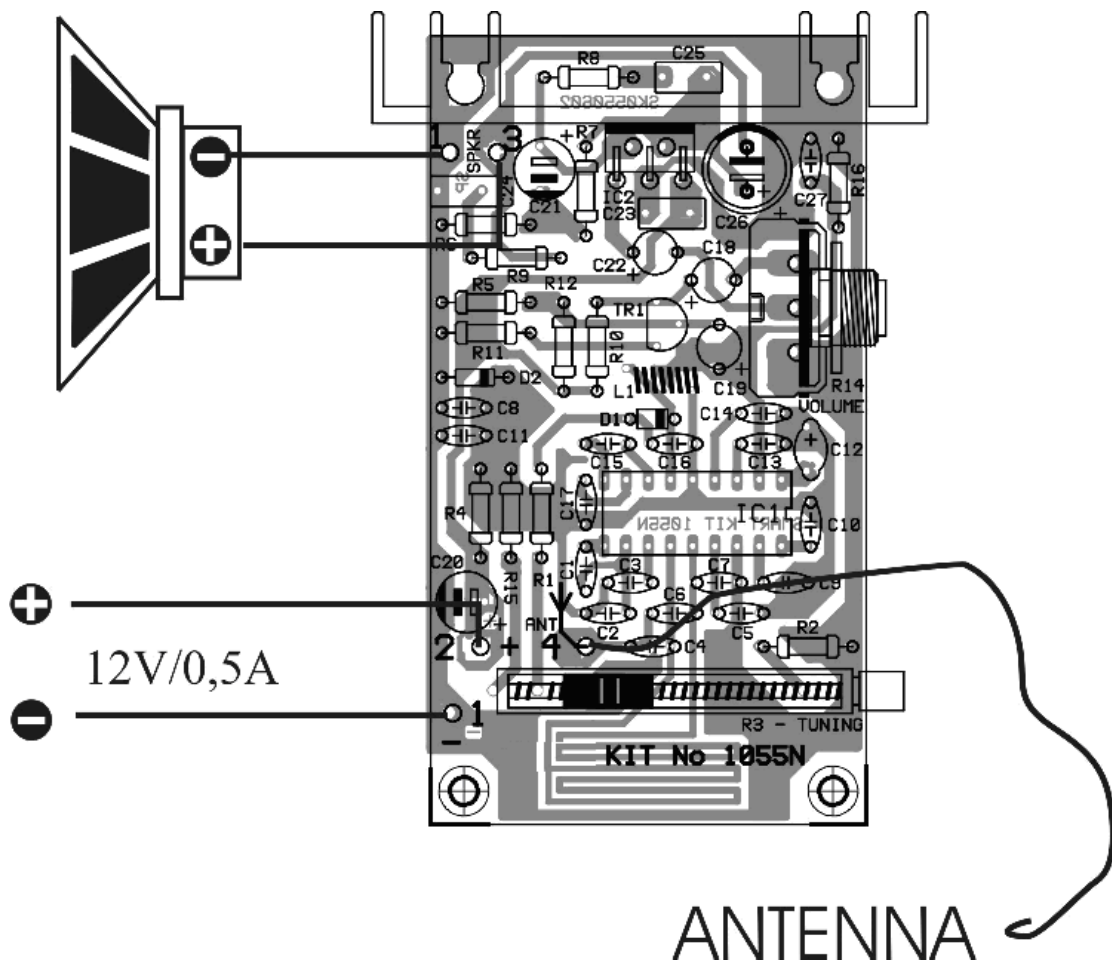
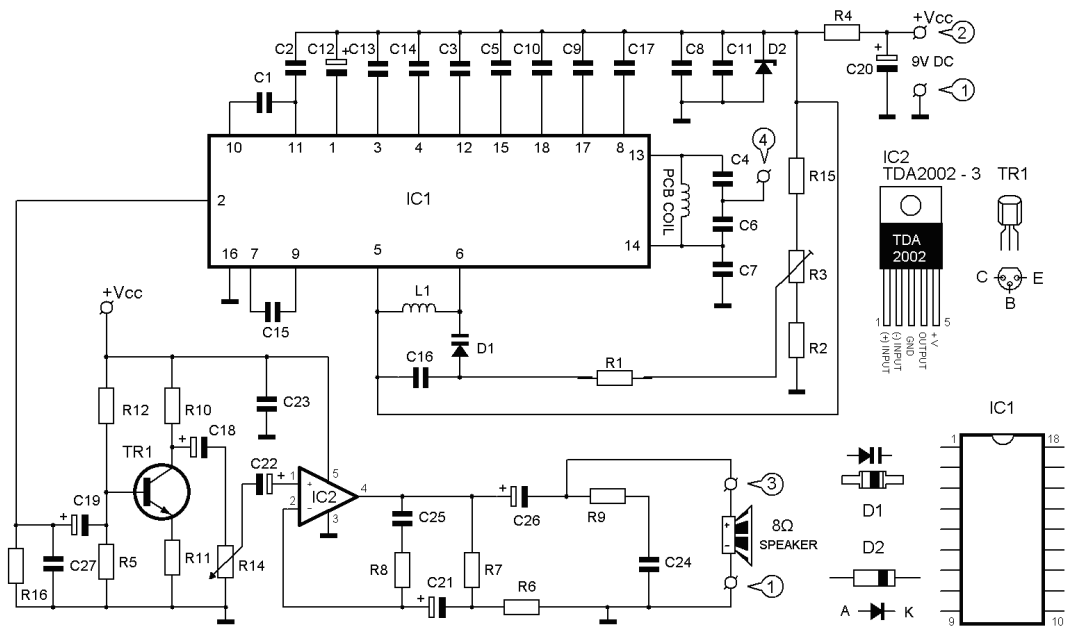

Ordering

For pricing info and online ordering please visit:

<http://www.quasarelectronics.com/1055.htm>

For further info please contact us by e-mail:

[mailto: sales@QuasarElectronics.com](mailto:sales@QuasarElectronics.com)

COPYRIGHT © 2010 Quasar Electronics Limited. All rights reserved.
Reproduction of this document in whole or in part in any form or medium
without express written permission of Quasar Electronics Limited is
prohibited.

E&OE