

QUASAR PROJECT KIT # 3126 - MINI-VOX & RELAY

General Guidelines for Electronic Kits and Assembled Modules

Thank you for choosing one of our products. Please take some time to carefully read the important information below concerning use of this product. The assembly and operating instructions are on the following pages.



WEEE Directive (Waste Electrical and Electronic Equipment)

Notice To All European Union Citizens. Important environmental information about this product.

The crossed out wheeled bin symbol on this product, package or documentation indicates that disposal of this product after its lifecycle could harm the environment. Do not dispose of this product (or batteries if used) as unsorted municipal waste. It should be disposed by a specialized company for recycling.

The unit should be returned to your distributor or to a local recycling service. Please respect the local environmental rules. If in doubt contact your local authorities about waste disposal rules.

Safety: General rules concerning safe use of our Kits or Modules.

To ensure your safety, please observe these safety measures. In no way are these complete. As safety requirements vary, please check with your local authorities, in order to comply with local requirements. If in doubt, seek the help of a qualified person.

Battery or wall-adaptor operated devices are safe devices. They do not require special attention unless mains voltage is connected to an output e.g. a relay.



To ensure electrical safety, and also protection from fire or personal injury, make sure your mains operated equipment complies with these safety hints:

- Use a suitable plastic enclosure. If a metal enclosure is used, make sure it is properly earthed.
- Use a power switch if the device consumes more than 10W. Use a double pole switch for mains operated, transformer-less kits.
- Mount a fuse in series with the mains switch. Use a slow blow (T) 50mA fuse for transformers up to 10W and a 100mA fuse for transformers up to 20W.
- Use a mains input connector, or a robust power cord with a clamp.
- Internal wiring carrying mains voltages must have a minimum cross-sectional area of 0.5mm².

If supplied, attach the power rating label near the power cord of the device and fill-out the mains voltage, frequency, power consumption and fuse values.

Troubleshooting and Support

90% of non working kits are due to poor soldering.

We operate a Get-You-Going service for non-working kits but there is a charge based on the time and components needed to complete the repair. Quite often it is not economically viable for us to repair and it is cheaper to supply a new ready made product at full cost.

Disclaimer

Quasar Electronics reserves the right to change product specifications or to discontinue products without notice. Quasar Electronics cannot be held responsible for any loss or damage, direct or indirect, which might occur from the use of a product. Quasar Electronics Kits or Modules are intended for educational and demonstration purposes only. They are not intended for use in commercial applications. If they are used in such applications the purchaser assumes all responsibility for ensuring compliance with all local laws. In addition, they are not suitable for use as or as a part of life support systems, or systems that might create a hazardous situation of any kind.

QUASAR PROJECT KIT # 3126 - MINI-VOX & RELAY

This mini-VOX - voice operated relay - is based on a circuit published in *Silicon Chip*, 9/1994, p31. We have improved it by putting an on-board Koa potentiometer in order to adjust the sensitivity. The idea behind a VOX is that instead of the user pressing a switch to activate a relay, the sound of the users voice itself activates the relay. This gives hands-free control over devices like tape recorders. The output can switch up to 30Vac/dc, 1 Amp.

Assembly. Check of the Components against the listing. Follow the overlay. Note that if the the relay is triggering continuously then it may be necessary to located the mic some distance away from the board (like 1ft to 2 ft) using 2-core cable (not supplied). This problem is caused by vibration from the relay itself. Also note one component is located under the IC so the IC socket has to be used.

Operation. Audio is picked up by the microphone and fed to the opamp IC1a. This is connected as a non-inverting amplifier with a gain of 151 or +43.6dB. The 100pF capacitor across the 150K feedback resistor rolls off the high frequency response above 10kHz to eliminate RF. The output at pin 1 feeds two diodes, D2 and D3 which function as a half-wave voltage doubler. These rectify the audio signal to produce a DC voltage across the 2.2uF ecap, C2 which is directly proportional to the input audio sound level.

This DC voltage is fed to pin 5 the second opamp IC1b. This is connected as a comparator. A resistive voltage divider applied about 2V to pin 6. Once the DC voltage across the 2.2u ecap rises above the voltage at pin 6, pin 7 pulls high. This turns on transistor Q1 which activates the relay and turns on the LED. Q1 remains on while the DC voltage at pin 5 is above that at pin 6. Because of the high opamp gain of IC1a, and with the voltage doubler gain the circuit has a fast response time. However, the release time takes about 3 seconds determined by the time constant of C2, R5 (the 1M resistor) and the pin 6 threshold voltage.

D1 is connected across the relay to protect Q1 when the relay turns off (back-emf.)

Connect the microphone on leads up to 2 feet away from the PCB. Connect the negative of the microphone (the pin connected to the microphone case) to the -ve on the PCB microphone position.

Battery 12V power may be used. D4 acts as protection for the circuit in case power is connected the wrong way. Current drain when off is 5-7mA. It is about 35mA when activated. Sensitivity may be varied with the 200K Koa potentiometer. A good working VOX level is about R6+R9 of 150K. The off delay time may be adjusted by varying R3 and R4. Reducing R3 will result in a longer release time.

You could change the release time constant (C2 & R5) to say 30 seconds and use the VOX as a light switch with this delay time before turning off. Increase C2 to say 10u and R3 to 3M3.

Email sales@quasarelectronics.com if you have any questions. See our kit range at www.quasarelectronics.com

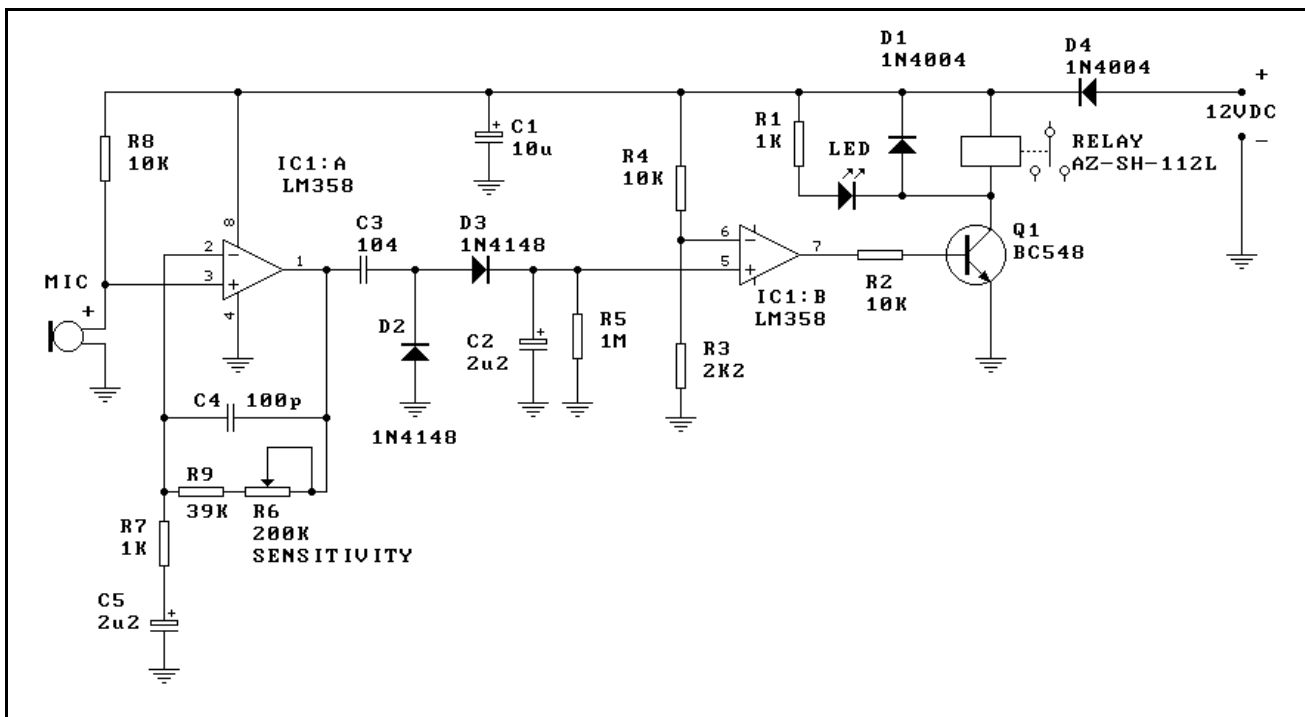

QUASAR PROJECT KIT # 3126 - MINI-VOX & RELAY

COMPONENTS

Resistors 5%, 1/4W:	
1K brown black red R1 R7	2
2K2 red red red R3	1
10K brown black orange R2 R4 R8	3
39K orange white orange R9	1
1M brown black green R5	1
200K 204 Koa potentiometer R6	1
1N4004 D1 D4	2
1N4148 D2 D3	2
2u2 mini ecap C2 C5	2
10u mini ecap C1	1
100pF 101 mono C4	1
.1uF 104 mono C3	1
BC548 Q1	1
LM358 IC1	1
8 pin IC socket	1
Relay AX-SH-112L	1
3 pole terminal block	1
Power jack	1
3mm LED	1
Electret microphone	1
3126 PCB	1