

## QUASAR PROJECT KIT # 3090H - STEREO 3W AMPLIFIER MODULE

**K**it 3090H is a class AB stereo audio power amplifier using a BA5406 module from Rohm. It is easy to construct and has a minimum of external components. This is the data book circuit which gives a high gain of 46dB, however it can be easily modified to suit your requirements by changing the two feedback resistors. We have supplied 1 kilohm resistors as an alternative, these provide 28 dB of gain, which will be more suitable with most pre-amps or PC sound cards etc.

### Specifications :

D.C. Input :	5 – 15V at 1 to 2 A
Power output :	> 3W RMS /channel, 4 ohm load, 12V DC supply. > 2W RMS /channel 8 ohm load 12V DC supply. > 2W RMS /channel, 4 ohm load 9V DC supply.
S/N ratio :	> 85 dB, G=28 dB. > 68 dB, G = 46dB.
THD	< 0.5% @ 1W.
Freq. Response :	40 Hz to 100 kHz –3 dB (G = 28 dB, 8 ohm load) 50 Hz to 25 kHz, G=46dB
Input level :	< 200 mV, for full output (G = 28dB) 20 mV, G = 46 dB
Input Impedance	~ 100 k ohm.

The supply voltage required for this kit is 5 - 15V DC at 1 to 2 Amps. Maximum output power will only be obtained with a power supply of at least 12V and greater than 1.5 A, using 4 ohm speakers. The power supply should be well filtered to reduce mains hum, as there are no on board filter capacitors. Filtering is unnecessary if operating from a battery supply, however if the supply leads are long, then a capacitor at the amplifier may be necessary. If using a mains transformer and rectifier, then an electrolytic capacitor of at least 1000 uF with a voltage rating of 16V or more, should be used.

### Construction.

Follow the printed circuit overlay with reference to the circuit diagram where necessary. Add the lowest height components to the board first, starting with the resistors. Be careful to get the electrolytic capacitors in the correct way around and all parts in their correct positions. Be careful when soldering the IC not to use excessive heat. Use some heat sink compound between the heat sink & the IC if possible. Use shielded signal wire for the input connections, and at least 16/0.2 hook up wire for DC input and speaker outputs. Try to keep lead lengths as short as possible

### Operation.

The circuit is straight forward. Most of the circuitry is contained within the amplifier module. C1 & C2 are input coupling capacitors and block DC, as do C9 & C10 which are the output coupling capacitors, and C4 & C7 which block DC from the feed back loop. R1 & R2 set the level of feed back.

The gain is equal to  $1 + (24k/R1) = 201$  (or 46 dB) for R1,R2 = 120 ohm, and 25 (or 28 dB) for R1,R2 = 1k ohm. There is no input attenuation provided, so if you require a volume control, then you should use an externally mounted dual gang, logarithmic potentiometer of between 10k ohm and 50k ohm. R3/C11 and R4/C12 provide a high frequency load for stability where loudspeaker inductive reactance may become excessive. C5 and C6 provide internal filtering for the input stage of the IC.

The maximum supply voltage for this Kit is 15V. Check the power supply voltage and polarity before connecting to the board. You should have no trouble in getting this kit to work. If yours does not work, first check all external wiring, make sure there are no shorts, then check all the component positions and orientation. Also check all solder joints and make sure there are no solder bridges.

You may download the full data sheet for the BA5406 IC from our website at :

<http://www.quasarelectronics.com/3090h.htm>

# QUASAR PROJECT KIT # 3090H - STEREO 3W AMPLIFIER MODULE

## Circuit Diagram

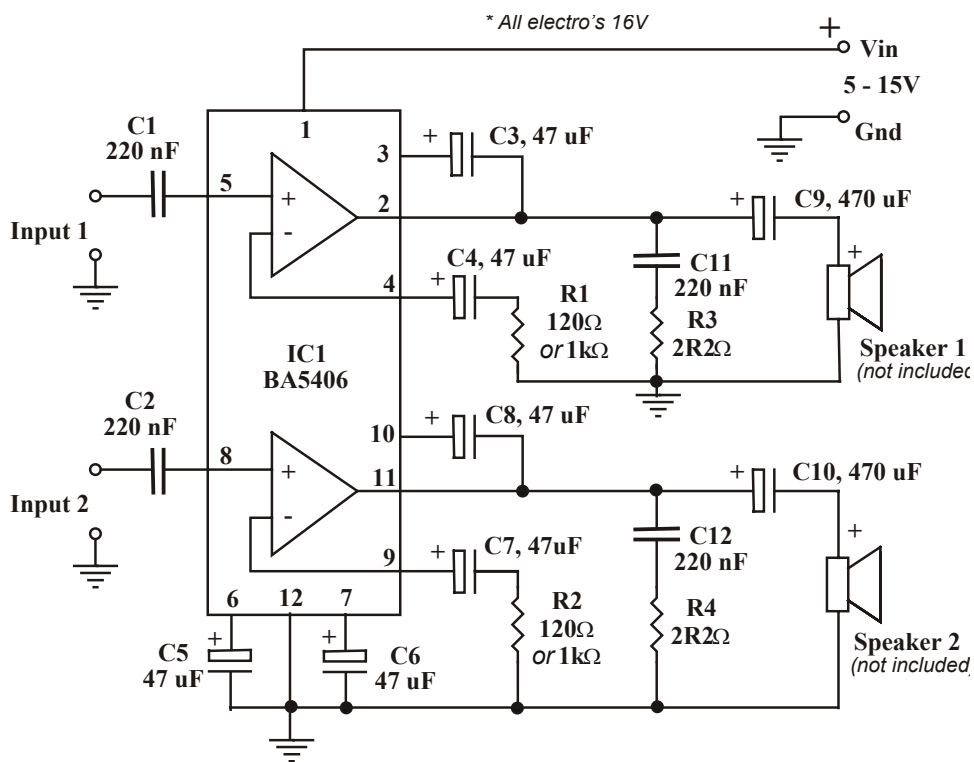

### Components

Resistors : 1/2W, 5%.		Qty.
R1, R2	120 ohm (brown red brown)	2
<b>OR</b>	(both supplied in new kits)	
R1, R2	1k ohm (brown black red)	2
R3, R4	2R2 ohm (red red gold)	2
<b>Capacitors :</b>		
C1, C2, C11, C12	220 nF (224) polyester	4
C3, C4, C5, C6, C7, C8	47 uF 16V ecap	6
C9, C10	470 uF 16V ecap	2
<b>Misc.</b>		
	BA5406 amplifier I.C.	1
	Heat sink HS210	1
	Nut & bolt set for HS	2 set
	3090 Printed Circuit Board	1

# QUASAR PROJECT KIT # 3090H - STEREO 3W AMPLIFIER MODULE

**Distortion @ 1W RMS Output  
1 kHz input and 12V DC supply.**

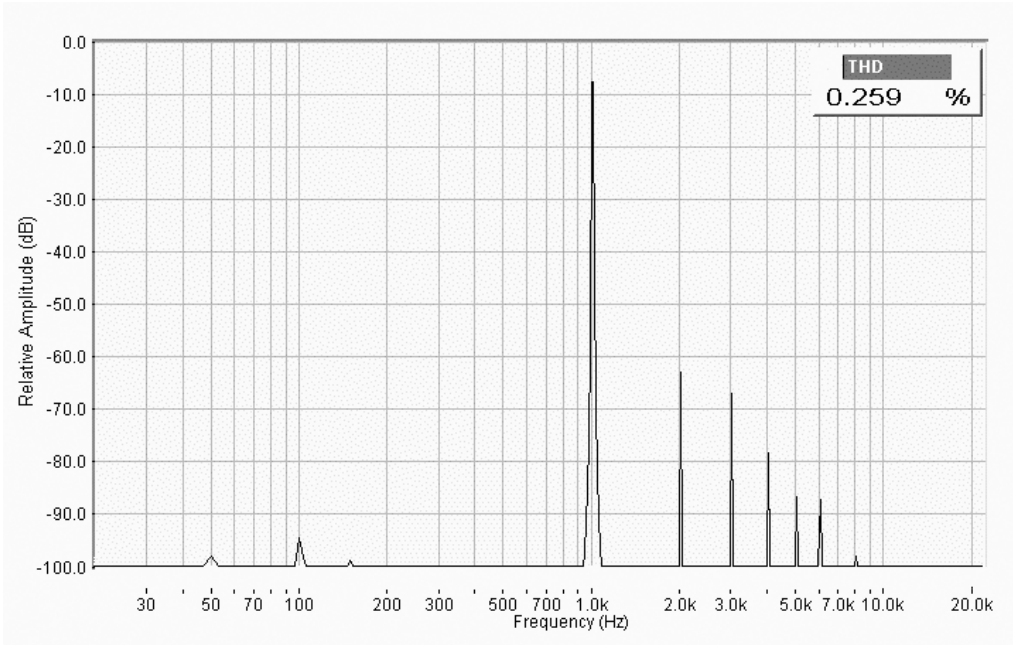

**Photo of completed Kit.**

