

120 Second Message Recorder with ISD25120 ChipCorder IC (Order Code 3064)

Information Storage Devices are one of the leaders in solid state audio recording & playback devices. The latest ISD2500 series provides high-quality, single-chip, non-volatile record/playback for 45, 60, 75, 90 and now 120 seconds. These CMOS devices include an on-chip oscillator, microphone preamplifier, automatic gain control, antialiasing filter, smoothing filter and speaker amplifier. In addition it is micro-processor compatible allowing complex messaging and addressing to be achieved.

Recordings are stored in on-board non-volatile memory cells, providing zero power message storage. The proprietary storage method allows natural voice analogue storage. The purpose of this Kit is to introduce you to this modern, new technology.

Our Circuit. We now use the ISD25120, 120 second audio recording IC in this kit. The ISD25120 has several modes of operation We use it here as a multi-message recorder. You may record as many messages as you want up to 120 seconds of memory space. Put the SPDT switch into the Record position and just push & release the Start/Pause button to start recording. The Record LED goes on. Push the Start/Pause button to Pause - stop recording. That is the end of Message 1.

Sometime later you can record a follow on message, Message 2, by pushing the Start/Pause button again. When you put the switch to Play the messages will playback. Only one message will be played back at a time. You must push Start/Pause again to get the next message. The Reset switch will move the internal address pointer back to the start of the memory space.

Removing the power will not destroy the messages. You may, for example, record a long message, then send just the IC to someone through the mail then the friend could playback your message. This is the same as the 20 second Greeting Cards now on the market. They use a ISD1420 chip-on-board IC.

Build up the Kit and start playing with it. Far better to learn about it from actual use than reading pages about how it works!

You can get more about applications and memory addressing of the ISD2500 ChipCorder series from:

<http://www.isd.com>

This URL routes to the Winbond site who own ISD. You can get the full IC datasheet from there.

Construction. We have placed some of the components underneath the IC. This was not only to reduce the size of the PCB. Because the ISD products are top quality we wanted to follow their recommended audio design practices:

- analogue components are placed physically close to the IC with short leads
- analogue and digital power & ground tracks have been kept separate
- large power & ground tracks have been used as much as possible even between IC pads

R1 & R8 are just able to squeeze in between the sides of the IC socket. If there is a problem use your soldering iron to burn a small groove in the IC socket.

The 1uF mini electrolytic capacitor C7 will fold over next to R11 quite comfortably. **NOTE:** there is one link to make under the socket. Use some wire cut off from a resistor to make the link.

Operation

Attach a **REGULATED** 6Vdc supply (not more!) to the power input terminal and an 8 Ohm or 16 Ohm speaker to the Output terminal.

If you want more loudness ISD suggest that one way to do so is to limit the low end frequency response. With C4 & C6 at 0.1uF, signals above 160Hz are not attenuated. Changing these capacitors to 0.01uF increases this low end pole to 1500Hz. Since small speakers do not reproduce the low frequencies efficiently this change may give you an increase in loudness.

If you want to amplify the output the differential output may be fed directly to audio equipment with a differential input. Or you may use an amplifier like an LM386. If you use the amplifier between one output pin (either pin 14 or 15) and ground it is very important that the unused output pin not be grounded. It must be left unconnected.

If It Does Not Work. Check that the diodes are all in the correct way. Are the resistors in the right places. Check that the TO-92 packaged components are in their correct places. Are the capacitors, microphone & LEDs the correct way around.

More on the ISD2500 ChipCorder Series

The power of the chip lies in the fact that the memory space is computer addressable. In the ISD2500 there are 600 (six hundred) addressable message segments. So in the ISD2560, for example, you can record a maximum of 600 messages each 100 msec long. So who wants 600 1/100th second messages? Well think of a talking voltmeter. No more would you have to put the probes on then move your head & eyes to read the display. The meter would say "six point two five volts". The spoken numerals plus the teens, tens & other quantifiers would only occupy the exact memory space they need to the next 1/100th of a second. The micro-controllers job is to quickly search through the address space and put together the required message output in real time.

120 Second Message Recorder with ISD25120 ChipCorder IC (Order Code 3064)

Think of a burglar alarm system: both the setting of it and the spoken messages it could give (over the phone after using the DTMF tones of phone numbers stored in ISD2500 memory too) after it was set off. Think of setting a VCR: instruction about how to set it can be spoken to you. And there would even be space for 'Have a nice day at the end of it.

Also ISD2500 chips can (with one exception) be seamlessly connected together to give increased message time. By seamless is meant that a message can straddle 2 physical IC's. (Earlier ISD chips could not do this.) See the Jeff Bachiochi article for more details.

References:

Bachiochi, Jeff. (1994). Build the Message Board. Circuit Cellar Ink/The Computer Applications Journal 45, April, 54 - 61. (Uses ISD2500 under computer control.)

Yates, Darren. (1994). Build this 90-second Message Board. *Silicon Chip*, February, 16 - 19. (Uses ISD2590.)

For other voice recording Kits and our 40 Second Voice Recorder with Loop (Order Code 3146) version.

<http://www.quasarelectronics.com/3064.htm>

COMPONENTS

Resistors:	
680R blue grey brown R5 R6	2
1K brown black red R7	1
4K7 yellow violet red R2	1
10K brown black orange R8 R9	2
22K red red orange R3 R4	2
100K brown black yellow R10 R11	2
470K yellow violet yellow R1	1
Capacitors:	
0.1 Monoblock 104 C1 C2 C4 C6	4
1uF electrolytic mini C7	1
4.7uF elcap C8	1
100uF elcap C3	1
220uF elcap C5	1
BC547 Q1 Q2 2	2
BC557 Q3	1
ISD25120 IC	1
28 pin IC socket	1
1N4148 diode	1
2 pole terminal block	2
Electret Microphone	1
Hat keyswitch	2
5mm LED	2
3064 PCB	1
SPDT PCB mounted switch	1

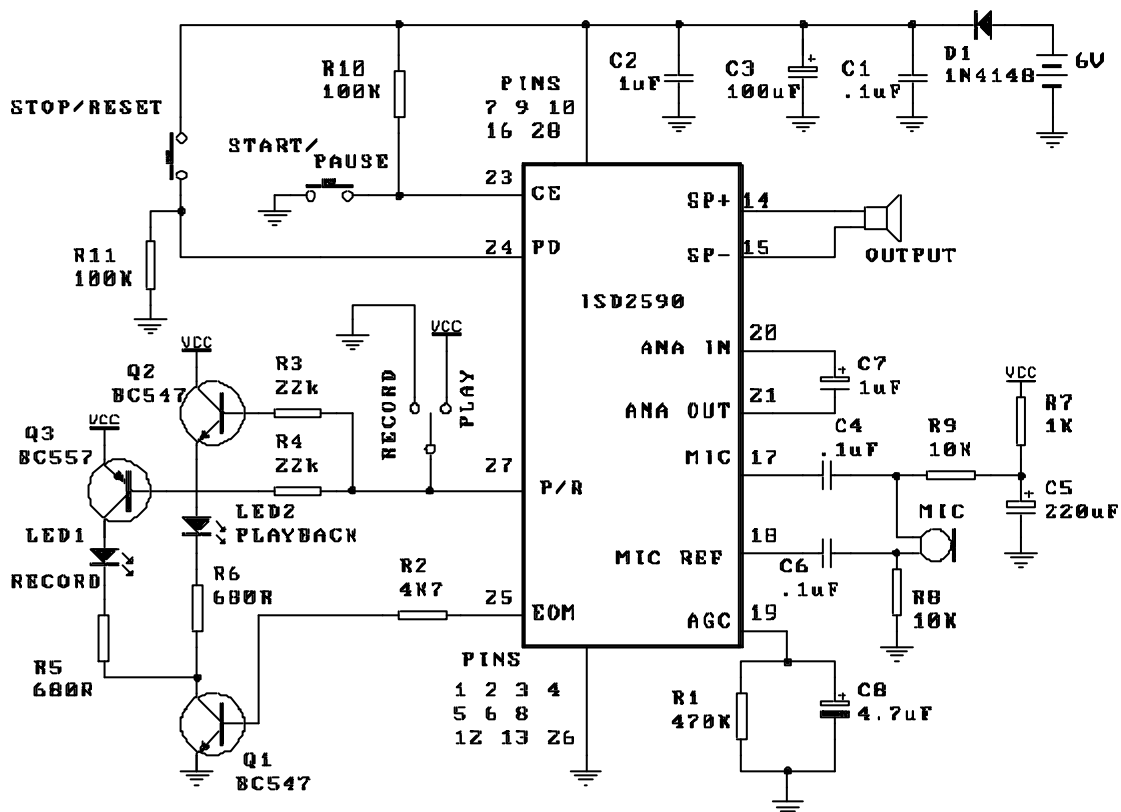

3064/3146 Addendum

Modification for Line In Recording

It is possible to make a simple modification to the 3064/3146 PCB to enable higher quality recordings to be made using a Line In audio signal from for example a PC sound card.

Please proceed as follows, referring to the schematic for further guidance:

1. Remove capacitor C7 (1uF) that connects to pins 20 and 21 of the IC
2. Remove capacitor C4 (100n) that connects the MIC to pin 17 of the IC
3. Connect a suitable Line In connector - the audio signal positive must go to pin 20 (ANA IN) of the IC via a 100n (0.1uF) capacitor and the audio signal ground must go to pin 26 (GROUND) of the IC. The tip (centre) pin) of the line out audio lead is normally positive.

Schematic Diagram

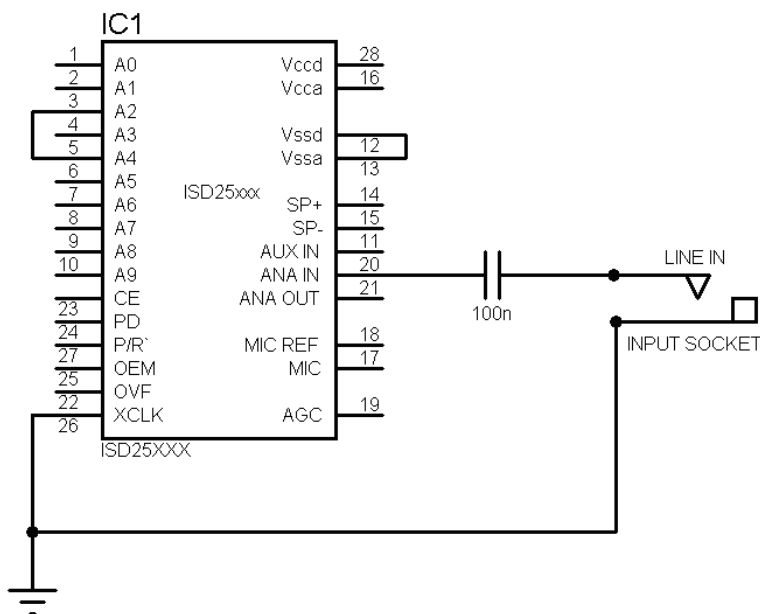

Making It Louder

It is possible to increase the sound output by using an external audio amplifier. ISD recommend the LM386 low voltage audio amplifier IC. Our 3017 Mono Amplifier Module uses the LM386 and is therefore an easy way to accomplish this. Full details can be found at <http://www.quasarelectronics.com/3017.htm>.

For best results a 100n capacitor should be used in series with SP+ and SP- outputs and the amplifiers inputs. For further information please refer to the ISD document entitled Application Brief 6A that can be found on our website at <http://www.quasarelectronics.com/ds/isd-ab6a.pdf>.